

- Reinforced Safe-T Rim**
 Our unique one-step manufacturing technique creates smooth, rolled edges to protect from cuts during handling and to strengthen the rim.
- Integrated Installation Rails**
 Our manufacturing process creates and forms installation rails as the bowls are pressed, as opposed to the traditional welding method of attaching them separately.
- No Welding**
 Our patented Press-Fit assembly or One-Piece Drawing eliminates the need for traditional welding. The result is a superior quality sink with no unsightly grind marks or center seam welds to buff or grind away.
- Sound-Deadening Pads**
 Pads cover the bottom of the bowl to insulate from excess noise and vibration.
- Easy Installation**
 Pre-Attached clips make installation simple. Simply drop in the sink; push side of clip in, pull down to lock and then slowly tighten the clip.



Made with premium grade "AISI" 304 stainless steel.

PRODUCT INFORMATION

Model #	Finish	Overall Dimension	Bowl Dimensions		Sink Depth	Cutout Dimension	Faucet Holes	Gauge	Shipping Weight
			Length	Width					
DMG703	Mirror Deck Gloss Bowl	33" x 22"	14"	15 1/2"	7"	32 1/4" x 21 1/4"	3	21	13 lbs.
DMG704	Mirror Deck Gloss Bowl	33" x 22"	14"	15 1/2"	7"	32 1/4" x 21 1/4"	4	21	13 lbs.

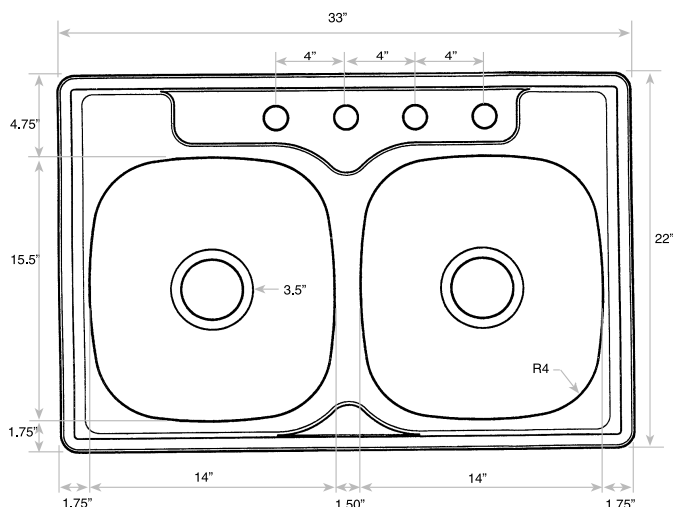

Corner Radius: 1"

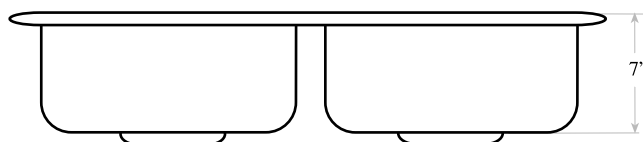

JOB NAME: _____

DATE: _____

CUSTOMER: _____

MODEL SPECIFIED: _____

NO. OF HOLES: _____ QTY: _____

ARCHITECT/ENGINEER: _____

CONTRACTOR: _____